

Main

Range of product	OsiSense XU
Accessory / separate part category	Sensor accessories
Accessory / separate part type	Reflector
Accessory / separate part destination	Standard reflex photo-electric sensor
Shape of reflector	Square
Sale per indivisible quantity	1

Complementary

Accessory dimension	50 x 50 mm
Net weight	0.04 Lb(US) (0.02 kg)

Packing Units

Unit Type of Package 1	PCE
Number of Units in Package 1	1
Package 1 Weight	0.71 Oz (20 g)
Package 1 Height	0.55 In (1.4 cm)
Package 1 width	3.46 In (8.8 cm)
Package 1 Length	2.99 In (7.6 cm)
Package 2 Weight	0.71 Oz (20 g)
Package 3 Weight	4.79 Lb(US) (2.174 kg)

Offer Sustainability

Sustainable offer status	Green Premium product
REACH Regulation	REACH Declaration
EU RoHS Directive	Pro-active compliance (Product out of EU RoHS legal scope) EU RoHS Declaration
Mercury free	Yes
RoHS exemption information	Yes
Environmental Disclosure	Product Environmental Profile
Circularity Profile	End Of Life Information

Contractual warranty

Warranty	18 months
----------	-----------

Dimensions

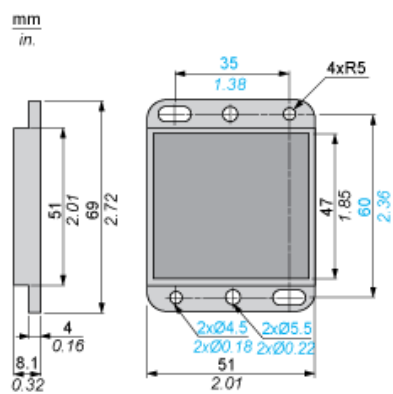

Product Life Status : Commercialised